

ProbePads 05



APPLICATIONS

- Device characterization
- Microwave integrated circuits
- On-wafer microwave measurements
- De-embedding

FEATURES

- Wire bondable Au contacts
- Eutectic, epoxy, or solder die attach
- Compact and low profile
- 99.6% Alumina
- Thin-film process

SPECIFICATIONS

TABLE 1: TYPICAL SPECIFICATIONS*

FREQ (GHz)	PART NUMBER	INSERTION LOSS (dB)	RETURN LOSS (dB)	SUBSTRATE	PROBE TIP SPACING	SIZE (MILS)
DC-26.5	PPS-005-01	0.25	20	99.6% ALUMINA	150-250 um	65 X 38 X 5

* Specifications subject to change without notice.

MECHANICAL

* Dimensions are inches

- 99.6%Alumina
- Metallization: Gold

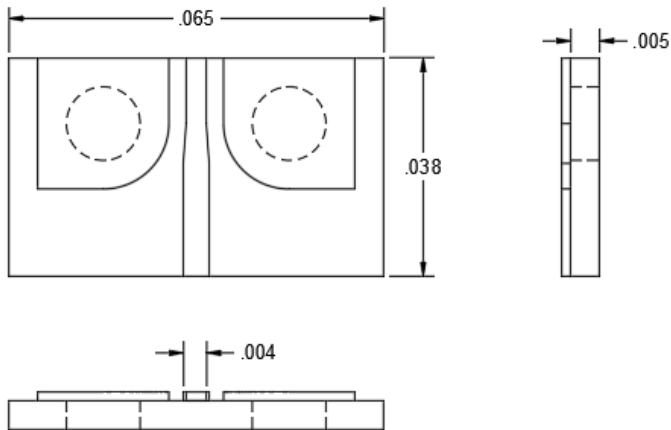

TYPICAL PERFORMANCE

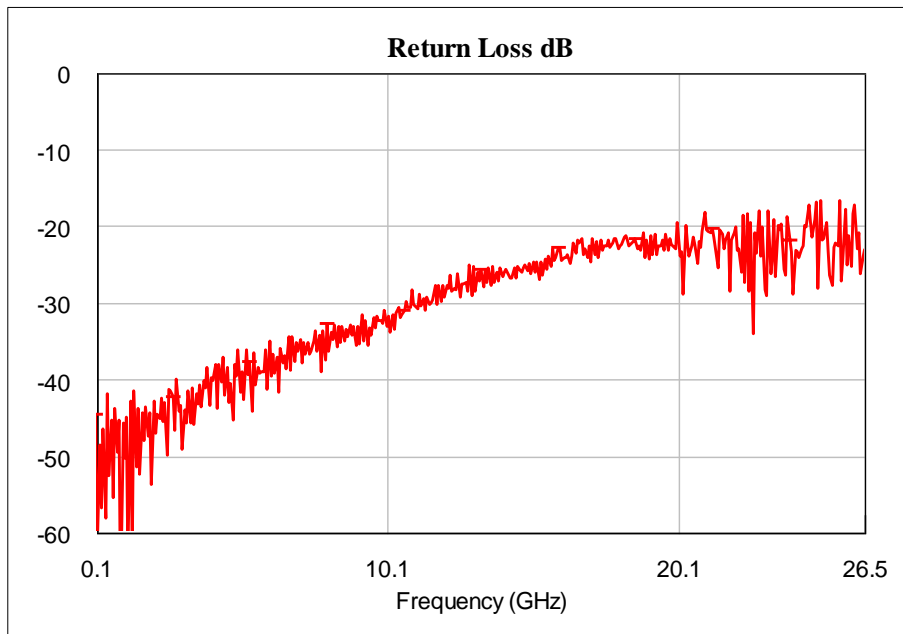
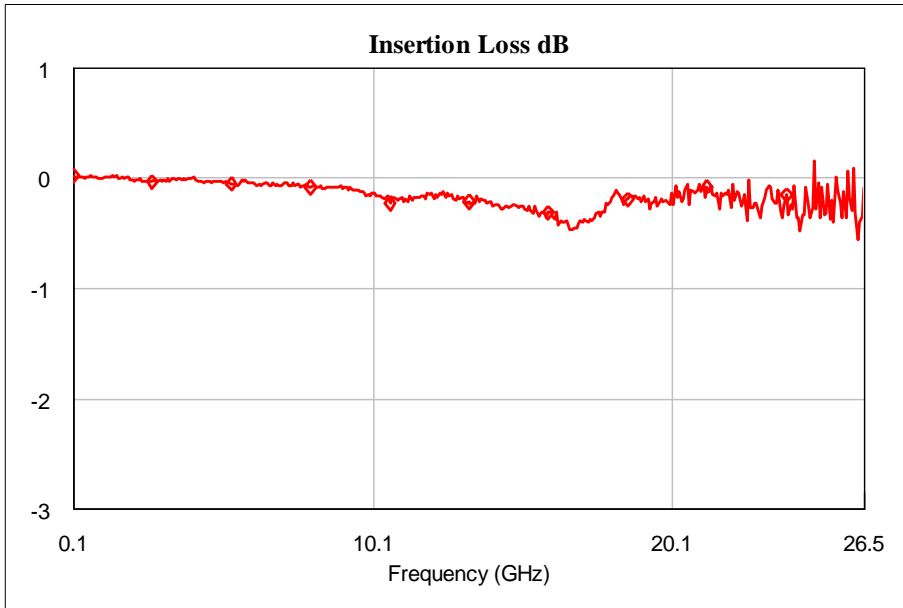

ProbePads 05

CPWG to microstrip transition

REV 1.1.0

Data taken with two back-to-back ProbePads 05 mounted on a gold-plated copper tungsten carrier with Epo-Tek H20E epoxy. Measured on a probe station with GGB EPC40-GSG-150 probes and CS5 calibration substrate.

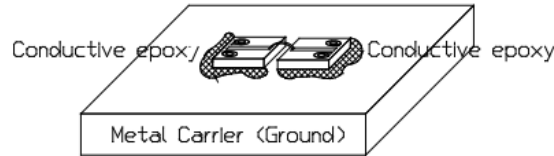

ORDERING INFO

P P S - 0 0 5 - 0 1
① ② ③

①	②	③
PRODUCT CODE		
CPWG TO MICROSTRIP TRANSITION	THK (mils)	-

Packaging: Waffle Pack

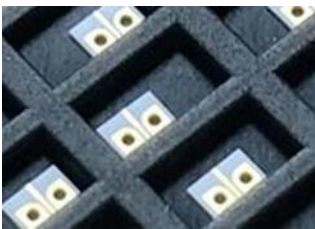

The PPS-005-01 is a lead free, RoHS compliant product.