

# Q3XD-665R

SURFACE MOUNT 3dB 90° HYBRID COUPLERS

REV 1.0.0

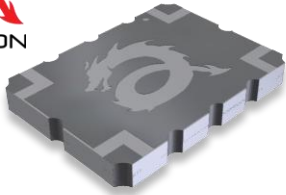

## APPLICATIONS

- Signal Splitting/Combining
- Balanced Amplifier Circuit
- I/Q Modulators/Demodulators
- Analog Phase Shifters
- Analog Variable Attenuators
- Microwave Mixers
- Image Reject Mixers

## FEATURES

- Excellent RF performance
- Low insertion loss
- Tight coupling
- Low amplitude balance
- Close phase tracking
- Industry standard sizes and footprint
- Dimensionally stable materials for best CTE match

## SPECIFICATIONS

TABLE 1: TYPICAL SPECIFICATIONS\*

FREQ (MHz)	POWER (W)	PART NUMBER	INSERTION LOSS (dB)	AMPLITUDE BALANCE (dB)	ISOLATION (dB)	VSWR	PHASE BALANCE	OPERATING TEMP (°C)	ΘJC (°C/W)
470-860	135	Q3XD-665R	0.20	± 0.35	20	1.20	± 2°	-55 to +95	14.3
470-665	200		0.12		26	1.15	± 1°		

\* Units tested with small signal using Electro-Photonics testboard at 25°C. Specifications subject to change without notice.

† Please consult sales ([sales@electro-photonics.com](mailto:sales@electro-photonics.com)) for custom footprints, sizes, and/or specifications.

## MECHANICAL OUTLINE

\* Dimensions are inches [millimeters].

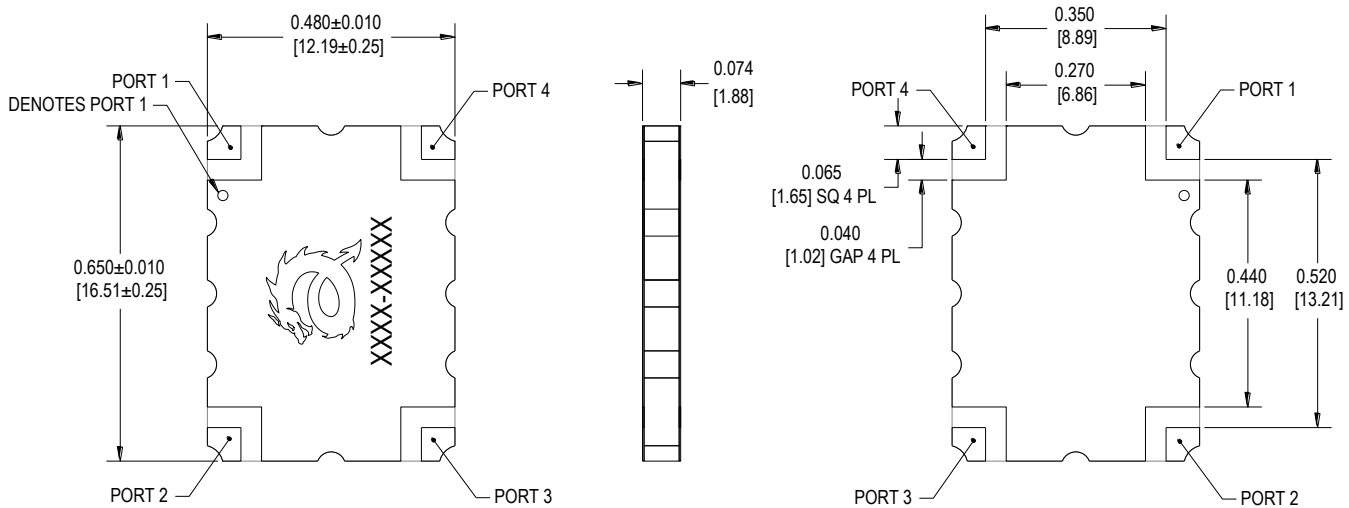

## TYPICAL PERFORMANCE

# Q3XD-665R

SURFACE MOUNT 3dB 90° HYBRID COUPLERS

REV 1.0.0

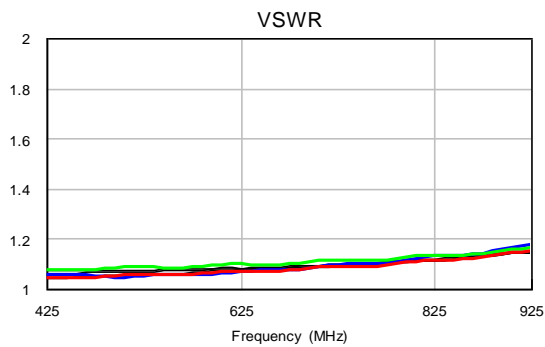
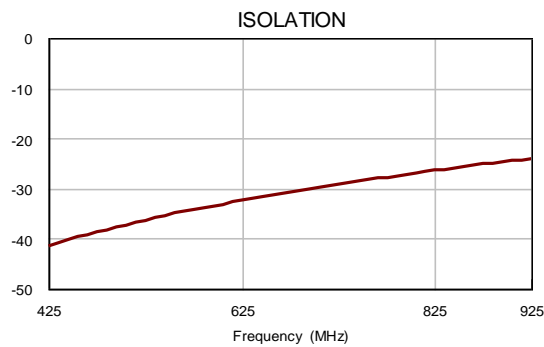
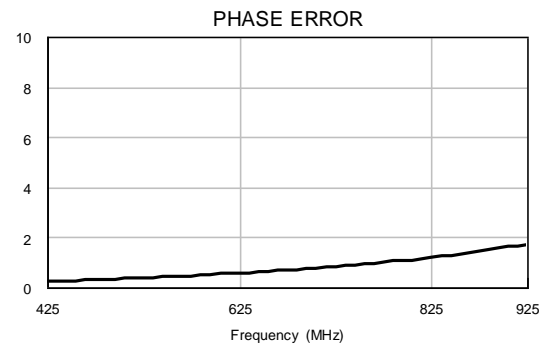
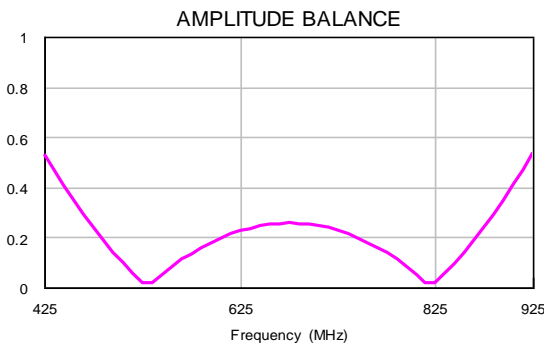
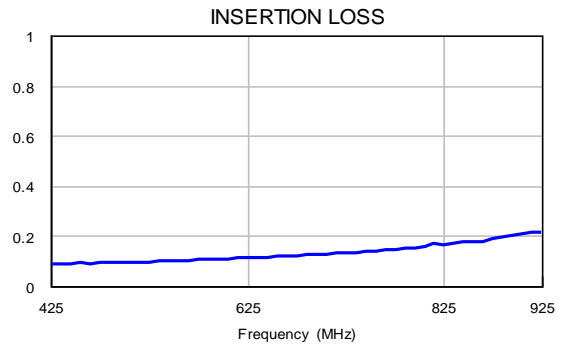
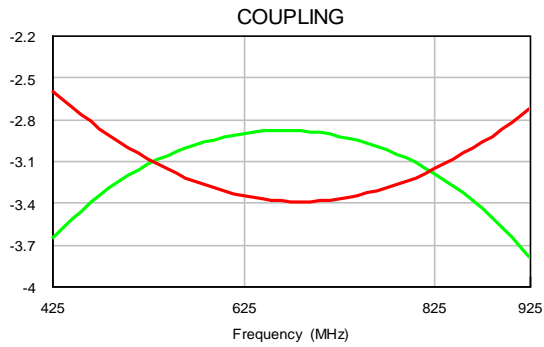

## POWER DERATING

COUPLERS

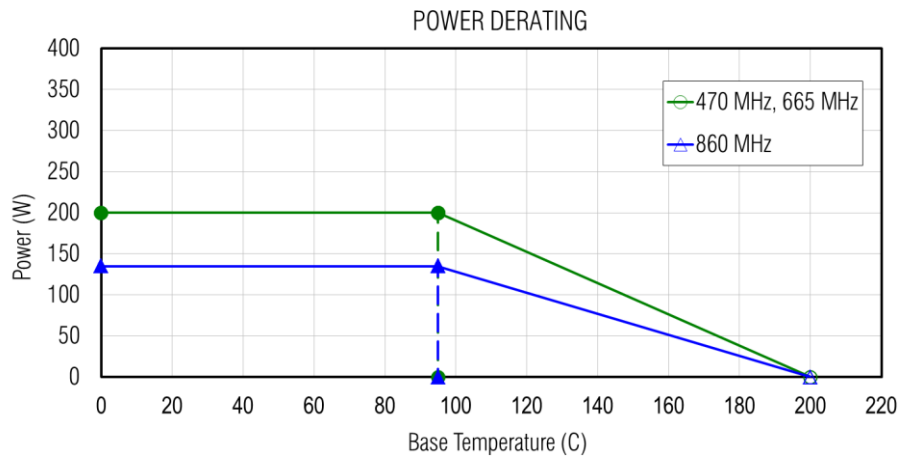

## PIN CONFIGURATION

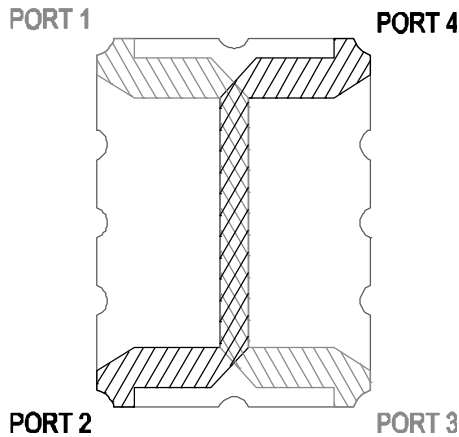

TABLE 2: SPLITTER CONFIGURATION\*

PORT 1	PORT 2	PORT 3	PORT 4
IN	ISO	-90°	0°
ISO	IN	0°	-90°
-90°	0°	IN	ISO
0°	-90°	ISO	IN

\* Signals will split into -3dB amplitude in quadrature. A small fraction of the signal will appear at the isolated port due to non-ideal isolation.

TABLE 3: COMBINER CONFIGURATION†

PORT 1	PORT 2	PORT 3	PORT 4
-90°	0°	ISO	OUT
0°	-90°	OUT	ISO
ISO	OUT	-90°	0°
OUT	ISO	0°	-90°

† Combining signals are applied in quadrature with equal amplitude. Unequal amplitude signals will generate small signal appearing at the isolated port.

## MOUNTING FOOTPRINT

# Q3XD-665R

Electro-Photonics test board is designed using 30 mil RO4350B material. Land pattern design must be taken into consideration when using a different thickness and/or dielectric constant in order for optimal performance.

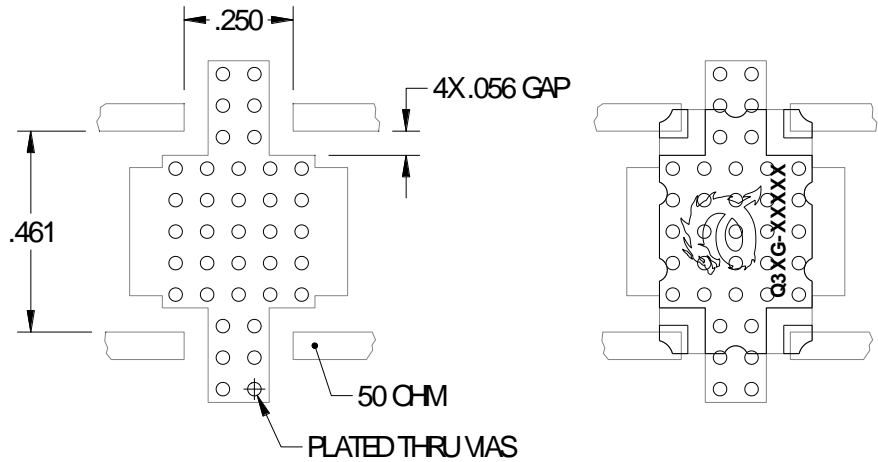

## ORDERING INFO\*

\* Consult sales ([sales@electro-photonics.com](mailto:sales@electro-photonics.com)) for custom configuration, size, footprint, and/or specifications. Tape & Reel available upon request (with minimum order quantities).

Q 3 X D - 6 6 5 R  
①      ②                      ③      ④

①	②	③	④
PRODUCT CODE	SIZE	FREQUENCY	PLATING
QUADRATURE 3dB CROSSOVER HYBRID	A = .250 X .200 B = .560 X .200 G = .560 X .350 D = .650 X .480	MHz (SEE TABLE 1)	R = IMMERSION TIN E = ENIG (ELECTROLESS NICKEL IMMERSION GOLD)



The Q3XD- 665R is lead free, RoHS compliant product.

COUPLERS